

PRODUCT TECHNICAL DATASHEET

BG30/1804/HS

Brushless 

Intensive use 

High Speed 

Digital Encoder 

Magnetic limit switch 



CODE	DESCRIPTION	PCS/PALLET
BG30/1804/HS	Electromechanical HIGH SPEED BRUSHLESS motor, low voltage, super intensive use, with native encoder onboard, irreversible ideal for sliding gates up to 1800 kg with built-in digital controller B70 series, with magnetic limit switch.	40

PRODUCT TECHNICAL SPECIFICATIONS	
Max gate weight	1800 kg
Power line supply	230V AC - 50Hz
Motor power supply	36V
Power rating	650W
Frequency of use	Intensive use
Thrust	50 - 1250N
Operating temperature	-20+55°C
Protection level	IP43
Reductor Type	Irreversible
Manoeuvre speed	18 m/min (0.30 m/s)
Limit switch	Magnetic
Onboard control unit	B70/1DCHP
Encoder	Digital native encoder + magnetic digital SENSORED, 4096 PPR
Batteries recovery	Optional 2 external battery 12V 4,5AH
Type exit gear	Z17/mod 4
Operating cycles per day (opening/closing - 24 hours no stop)	800

Maximum dimension product in mm (L x W x H)	346 x 180 x 362
Product weight packed (Kg)	20,1
Number items per pallet	40

PRODUCT DIMENSIONS AND PREPARING FOR INSTALLATION

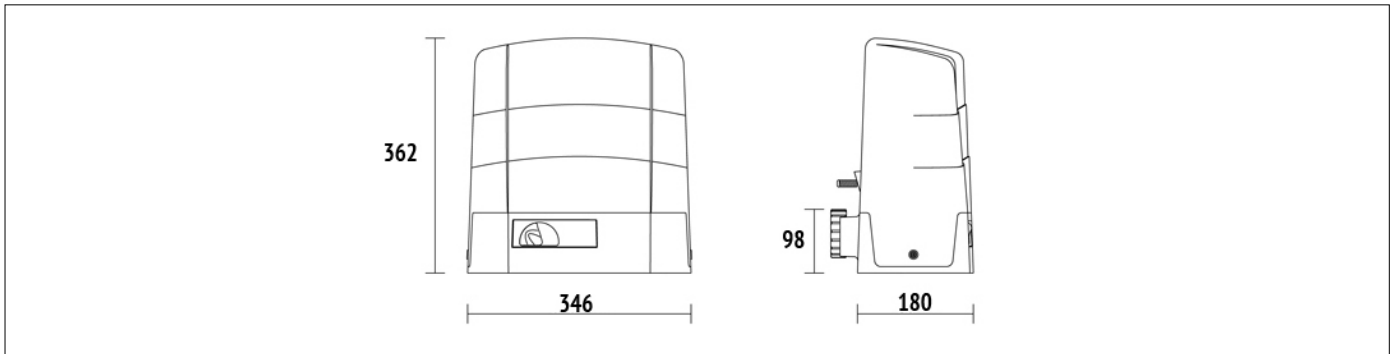

DIMENSIONS

PRODUCT PREPARING FOR INSTALLATION

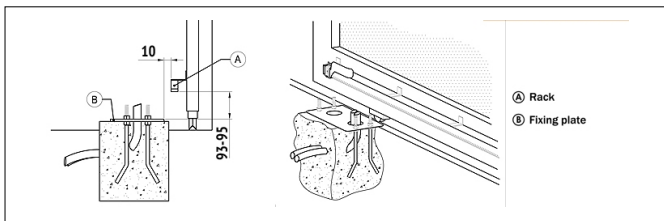

PREDISPOSITION FOR STANDARD INSTALLATION

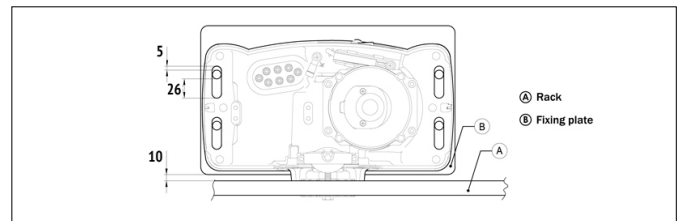

PRODUCT ACCESSORIES



B71/BCHP/EXT
Kit for emergency batteries charger for brushless digital controller EDGE1/BOX - B70/1DCHP 36V DC with plug-in card, with 2 recovery batteries 12V DC, 4.5 Ah. Box case included.



B71/BCHP/BOX
Kit for emergency batteries charger for brushless digital controller EDGE1/BOX - B70/1DCHP 36V DC. Box case included and without recovery batteries



B71/PBX36/BOX
Battery chargers with solar panels for powering Brushless digital controllers at 36V DC in network mode



B71/PBX36/BOX/115
Battery chargers with solar panels for powering Brushless digital controllers at 36V DC in network mode



B71/PBX/BOX
Battery chargers with solar panels for powering Brushless digital controllers in FULL SOLAR mode

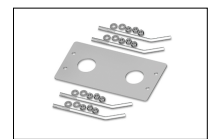

KT215
Fixing plate with stay bolts and screws G30 series.

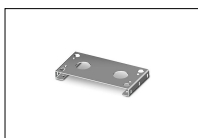

KT222
Raised fixing plate for G30 series (+3,5 cm).



GA550
Galvanised steel rack 22x22x1000 module 4.



GA551
Galvanised steel rack 30x12x1000 module 4 with spacers and screws.



GA554
Pocket of 6 spacers (2,5 cm) and screws.

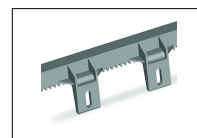

GA553
Nylon rack module 4 with 6 connectors L.1000.



GA557
Roger Technology nylon rack module 4 with 6 connectors L.1000.



LT328
Z17 mod. 4 Pinion with increased thickness H.38 for series R30 - G30 - E30



LT331
Pinion Z11 mod. 6 only for series G30 - BG30

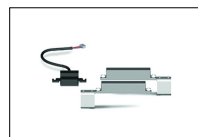

MC775
Kit magnetic limit switch for control unit H70/103AC, H70/104AC, B70/1DC, B70/1DCHP.

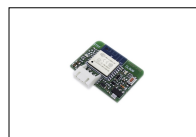

B74/BCONNECT
Module WI-FI B-CONNECT - Management and programming system in IP web mode, via P2P hot spot WI-FI connection for 36V brushless digital controller (EDGE1 - CTRL - CTRL/P - B70/1DCHP).



R99/C/001AL
Signboard "Automatic Opening" Aluminium version



R99/C/001
Signboard "Automatic Opening".