



# PRODUCT TECHNICAL DATASHEET

# G30/1804

- Optical encoder 
- Magnetic limit switch 
- 230V AC 



CODE	DESCRIPTION	PCS/PALLET
G30/1804	Electromechanical motor 230V AC irreversible ideal for sliding gates up to 1800 kg with built-in control unit H70, optical encoder and magnetic limit switch.	30

PRODUCT TECHNICAL SPECIFICATIONS	
Max gate weight	1800 kg
Power line supply	230V AC - 50Hz
Motor power supply	230V AC
Power rating	520W
Frequency of use	50%
Thrust	1200N
Operating temperature	-20+55°C
Protection level	IP44
Reductor Type	Irreversible
Manoeuvre speed	9.5 m/min (0.16 m/s)
Motor thermal protection	150°C
Incorporated condenser	18 µF
Limit switch	Magnetic
Onboard control unit	H70/104AC
Encoder	Optical
Type exit gear	Z17/mod 4
Maximum dimension product in mm (L x W x H)	346 x 180 x 362
Product weight packed (Kg)	19,5
Number items per pallet/box	30

# PRODUCT DIMENSIONS AND PREPARING FOR INSTALLATION

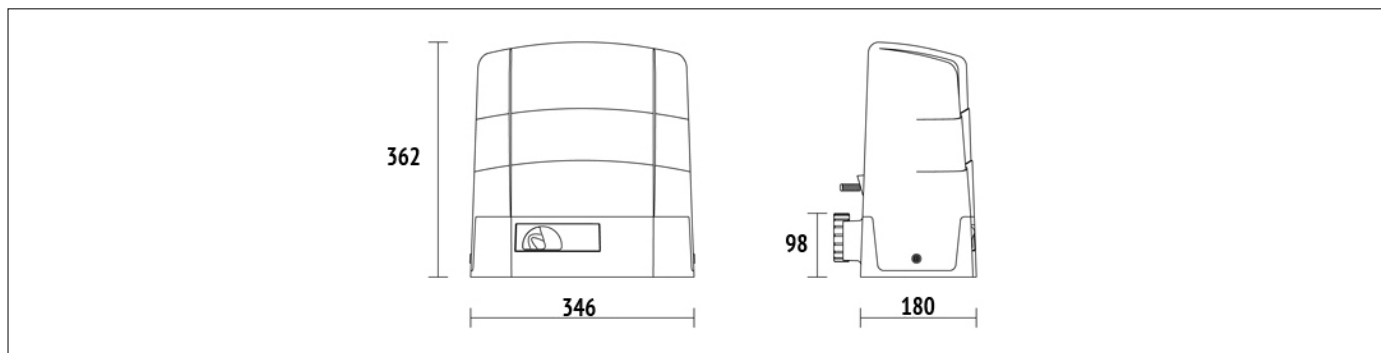

DIMENSIONS

## PRODUCT PREPARING FOR INSTALLATION

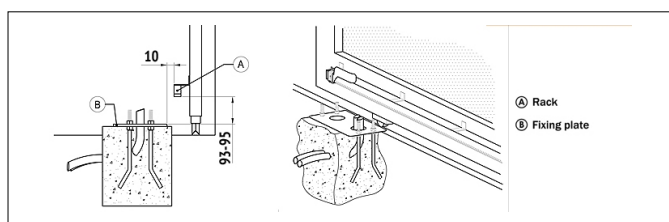

PREDISPOSITION FOR STANDARD INSTALLATION

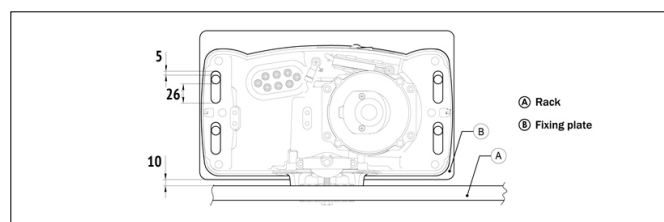

## PRODUCT ACCESSORIES

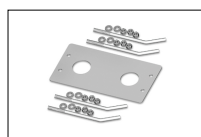

**KT215**  
Fixing plate with stay bolts and screws G30 series.



**KT222**  
Raised fixing plate for G30 series (+3,5 cm).



**GA550**  
Galvanised steel rack 22x22x1000 module 4.



**GA551**  
Galvanised steel rack 30x12x1000 module 4 with spacers and screws.



**GA554**  
Pocket of 6 spacers (2,5 cm) and screws.

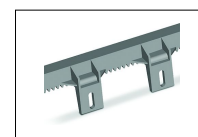

**GA553**  
Nylon rack module 4 with 6 connectors L.1000.



**GA557**  
Roger Technology nylon rack module 4 with 6 connectors L.1000.

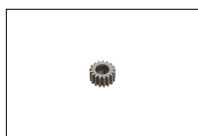

**LT328**  
Pinion Z17 mod. 4 with increased thickness H.38 for series R30 - G30 - TW110 - E30 (except BG30/804/HS - BG30/1504/HS - TW110/1000/HS).



**LT331**  
Pinion Z11 mod. 6 only for series G30 - BG30 - TW110 (except BG30/804/HS - BG30/1504/HS - TW110/1000/HS).

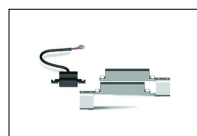

**MC775**  
Kit magnetic limit switch for control unit H70/103AC, H70/104AC, B70/1DC, B70/1DCHP.



**R99/C/001AL**  
Signboard "Automatic Opening" Aluminium version.

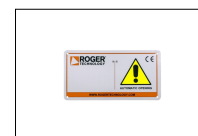

**R99/C/001**  
Signboard "Automatic Opening".